

Supplementary Material: Realization of high-fidelity CZ gates in extensible superconducting qubits design with a tunable coupler

Yangsen Ye,^{1,2,3} Sirui Cao,^{1,2,3} Yulin Wu,^{1,2,3} Xiawei Chen,² Qingling Zhu,^{1,2,3} Shaowei Li,^{1,2,3}
 Fusheng Chen,^{1,2,3} Ming Gong,^{1,2,3} Chen Zha,^{1,2,3} He-Liang Huang,^{1,2,3,4} Youwei Zhao,^{1,2,3}
 Shiyu Wang,^{1,2,3} Shaojun Guo,^{1,2,3} Haoran Qian,^{1,2,3} Futian Liang,^{1,2,3} Jin Lin,^{1,2,3} Yu Xu,^{1,2,3}
 Cheng Guo,^{1,2,3} Lihua Sun,^{1,2,3} Hui Deng,^{1,2,3} Xiaobo Zhu,^{1,2,3,*} and Jian-Wei Pan^{1,2,3}

¹*Hefei National Laboratory for Physical Sciences at the Microscale and Department of Modern Physics,
 University of Science and Technology of China, Hefei 230026, China*

²*Shanghai Branch, CAS Center for Excellence in Quantum Information and Quantum Physics,
 University of Science and Technology of China, Shanghai 201315, China*

³*Shanghai Research Center for Quantum Sciences, Shanghai 201315, China*

⁴*Henan Key Laboratory of Quantum Information and Cryptography, Zhengzhou 450000, China*

I. DEVICE SETUP

Our experiment is carried out on a 5-qubit superconducting quantum process, where two qubits are mainly manipulated. The device parameters are summarized in Table II.

	Q ₁	Q ₂
$\omega_r/2\pi$ (GHz)	6.403	6.477
$\omega_q^0/2\pi$ (GHz)	5.299	5.211
$\omega_q/2\pi$ (GHz)	5.077	4.889
T_1 (μ s)	20.56	26.32
T_2^* (μ s)	2.52	2.16
$\chi_{qr}/2\pi$ (MHz)	1.05	0.85
$U/2\pi$ (MHz)	-235	-235
f_{00}	0.993	0.996
f_{11}	0.966	0.974

TABLE S1. Device parameters: $\omega_r/2\pi$ is the frequency of readout resonator; $\omega_q^0/2\pi$ is the maximum frequency; $\omega_q/2\pi$ is the idle frequency; T_1 is the energy relaxation time of qubit measured at the idle frequency; T_2^* is the dephasing time of qubit measured at the idle frequency; χ_{qr} is the dispersive shift; U is the anharmonicity of qubit measured at the idle frequency; f_{11} (f_{00}) is the readout fidelity of |1⟩ (|0⟩), the rate of correctly measuring |1⟩ (|0⟩) when the qubit is prepared at |1⟩ (|0⟩).

II. EXPERIMENTAL SETUP

As shown in Fig. S1, our measurement system consists of a dilution fridge, control electronics and wiring. The quantum processor which consists of two chips is installed at the base temperature stage of the dilution fridge. There are 41 dB attenuation for XY control lines and 51 dB for readout lines at all stages in the dilution fridge. For qubit fast Z control lines, there is 31 dB attenuation at all stages, and 1050 MHz low pass filters are installed at cold plate stage. For coupler fast Z control lines, we need wider detune range so we attach 20 dB attenuation at all stages and 1050 MHz low pass filters at the base temperature stage. For qubit Z dc control lines, we have RC filters of 10 KHz cut-off frequency installed at 4 K stage and 80 MHz filters at cold plate stage. Qubit fast Z control line, dc Z control line and XY control line of are combined together with a bias T at cold plate stage. After three kinds of lines being combined together, we use 8 GHz low pass filter to lower high frequency noise. The readout signal firstly passes through a 8 GHz low pass filter and two circulators, then amplified by JPA [1]. The third circulator is attached also at the base temperature and all the three circulators are used to block noise from higher temperature stages. Next, the readout signal is amplified

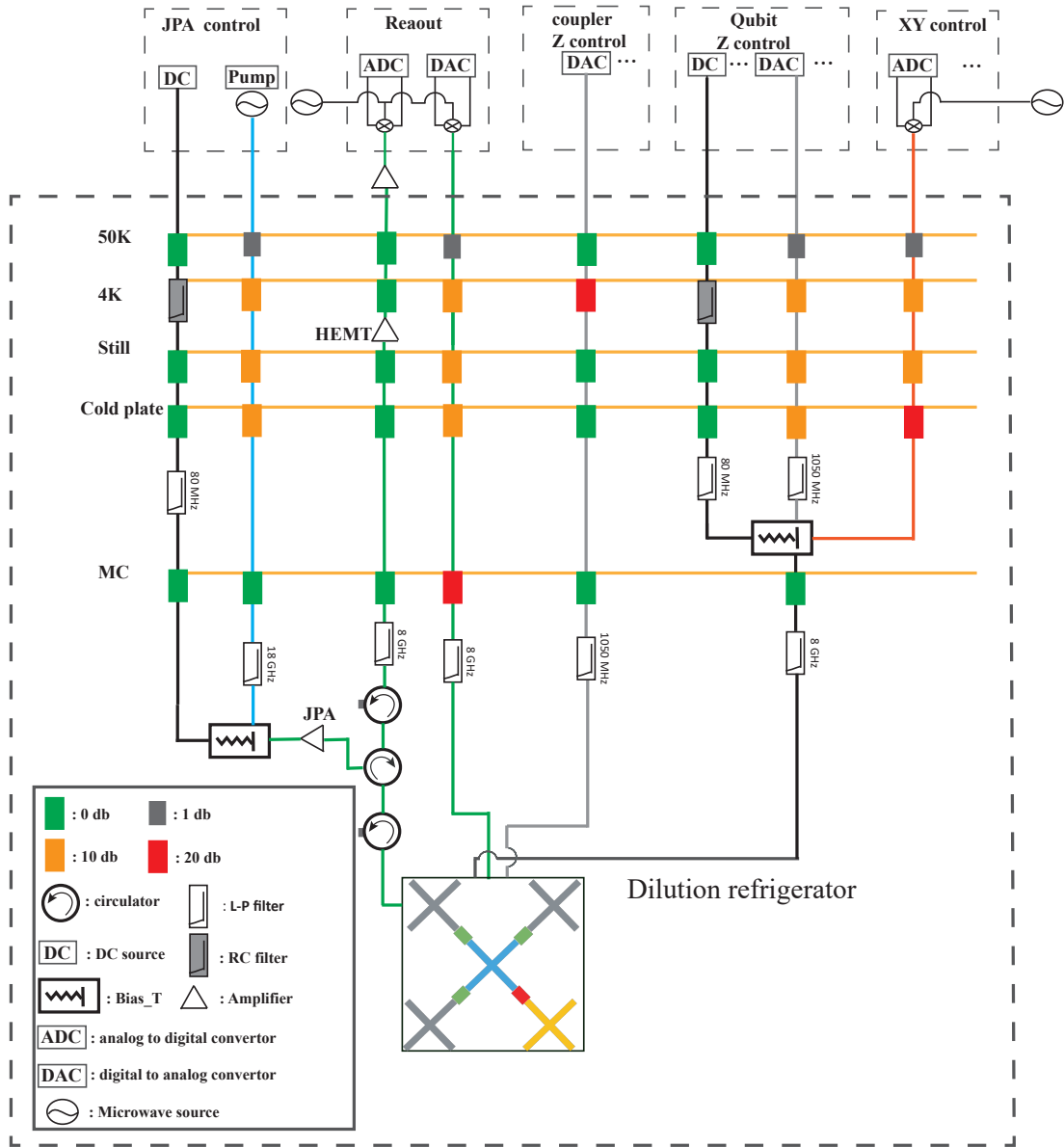

FIG. S1. The schematic diagram of control electronics and wiring.

by a high electron mobility transistor (HEMT) amplifier at 4 K stage, and then further amplified by a room temperature amplifier. Finally, signal is demodulated and digitized to extract the qubit-state information.

* xbzhu16@ustc.edu.cn

- [1] J. Y. Mutus, T. C. White, R. Barends, Y. Chen, Z. Chen, B. Chiaro, A. Dunsworth, E. Jeffrey, J. Kelly, A. Megrant, C. Neill, P. J. J. O'Malley, P. Roushan, D. Sank, A. Vainsencher, J. Wenner, K. M. Sundqvist, A. N. Cleland, and J. M. Martinis, *Applied Physics Letters* **104**, 263513 (2014).